

Envoy SC

Single-Channel Hall Effect
Current Sensor

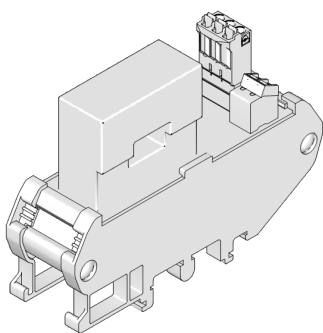

OVERVIEW

The Envoy SC is a single channel (SC) module designed for high-quality current measurements in the range from 50 to 300 Amperes.

The IsoBlock Current-FG uses Hall Effect with closed loop methodology to measure the current flowing in the conductor passing through the aperture. This is followed by an anti-aliasing filter and a conditioning stage to output a $\pm 10V$ signal.

The compact form factor of the Envoy SC module allows users to setup high channel density monitoring systems, making it ideal for deployed and portable systems.

SPECIFICATION

Envoy SC	50A	100A	150A	200A	300A
Bandwidth (-3dB point)	DC - 300kHz				
Integrated sensor noise (Referenced to input)	< 3.2 mA	< 6 mA	< 10 mA	< 15 mA	< 18 mA
Conversion Factor	200 V/A	100 mV/A	66.667 mV/A	50 mV/A	33.333 mV/A
Input dynamic range	50A	100A	150A	200A	300A

Electrical

Accuracy (percentage of reading) $\pm 0.7\%$

Gain

Max total phase shift at 60Hz < 0.01°

Max Input delay < 1 μs

Isolation voltage AC 3000V, for 1 minute

Insulation Resistance >500M Ω (@500V)

Thermal drift gain < $\pm 0.01\%$ / $^\circ C$

Mechanical

Mounting Type DIN Rail

Outer Dimensions 3.5" x 2.5" x 1.5"

Weight 205 g (7.2 oz)

Integrated sensor noise

Input-Output non-linearity < 280 ppm/A

Output voltage $\pm 10V, \pm 5V$ Custom

Gain temperature drift ± 50 ppm/ $^\circ C$

Differential input dynamic range

Power Supply Voltage 5V,9V,12V and 24V options

Output type Differential signal

Output Offset Voltage < $\pm 500\mu V$

Output impedance 100 Ω

Environmental

Operating temperature - 25 to 65 $^\circ C$

Storage temperature - 40 to 70 $^\circ C$

HARDWARE DESCRIPTION

The current sensing component of the unit is the aperture located at the top of the module in the figure above. Two connectors that serve to power the unit and output the sensor signal lays along the bottom.

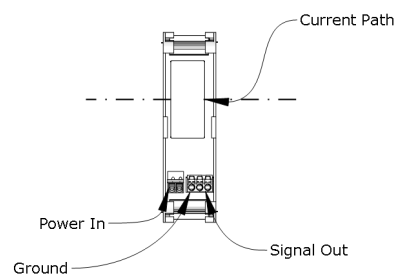

indication of input, output and power of the IsoBlock I-FG-1c

The IsoBlock Current module is designed to mount on standard NS-35 or NS-32 DIN rails with minimal preparation, providing users ease of use and flexibility.

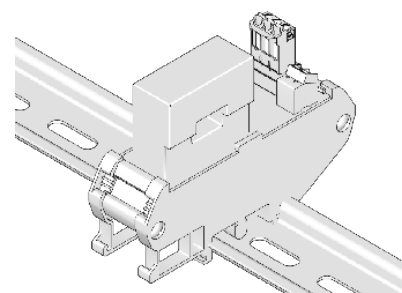

Installation on DIN rail

MERCHICAL DIMENSIONS

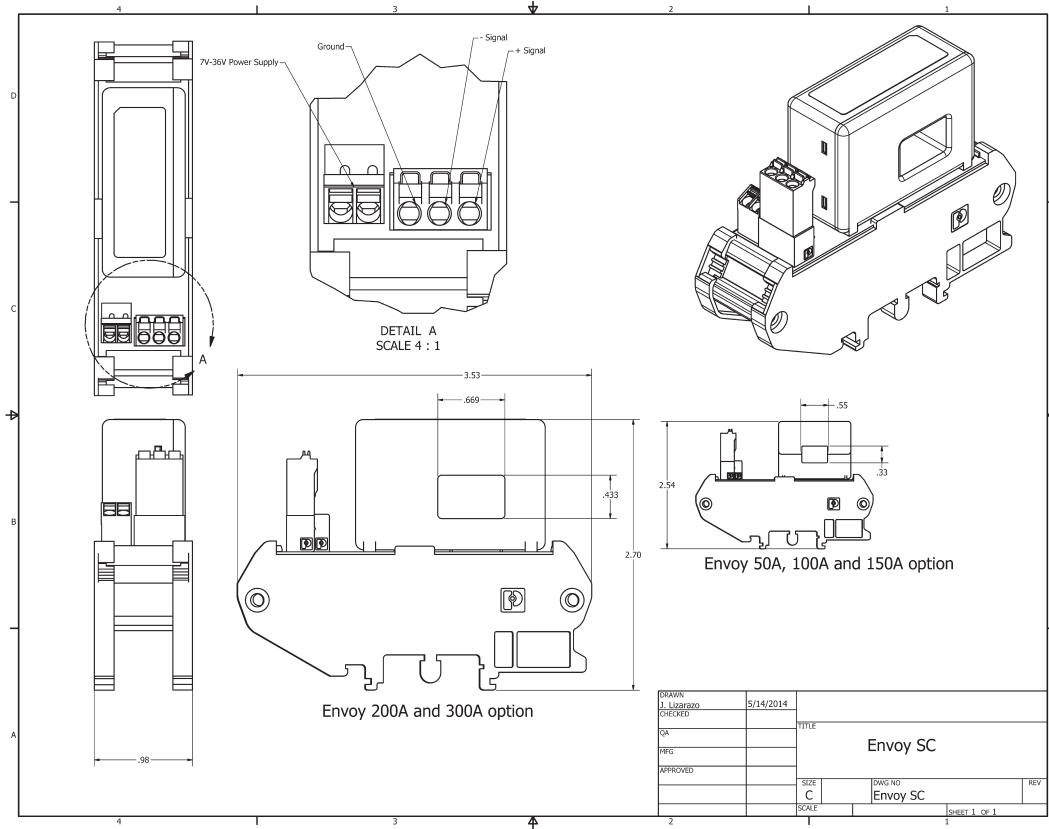

HARDWARE CONFIGURATION

A. Connect external power source to power the unit. For proper functioning the power supply should provide a voltage as specified with at least 0.25A of continuous current and 0.5A surge during module start-up.

B. Securely connect one end of a twisted pair to the output terminals, and the other end to the inputs of your data acquisition unit

C. Pass conductor through aperture and observe orientation for proper signal polarity.

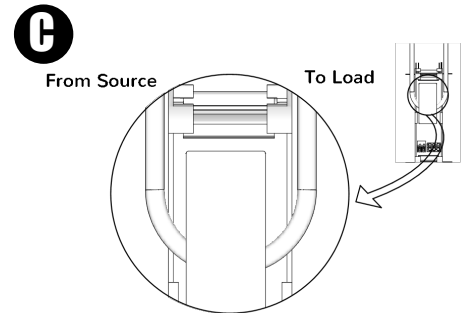
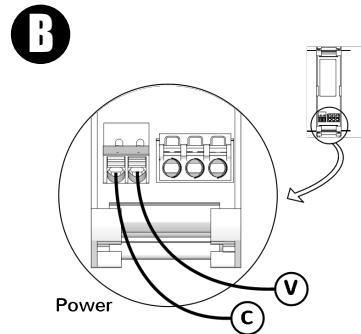
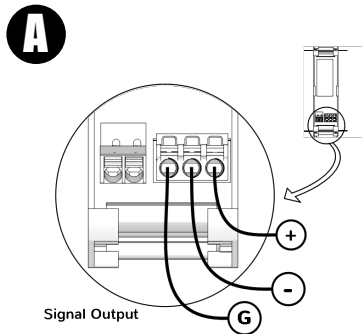

Standards and Certifications

- CE
- RoHS Compliant



THIS SENSOR IS NOT A SAFETY DEVICE AND IS NOT INTENDED TO BE USED AS A SAFETY DEVICE. This sensor is designed only to detect and read certain data in an electronic manner and perform no use apart from that, specifically no safety-related use. This sensor product does not include self-checking redundant circuitry, and the failure of this sensor product could cause either an energized or de-energized output condition, which could result in death, serious bodily injury, or property damage.